

	Available backlash: 1 - 2 stages	Available backlash: 3 stages	Gearbox output bearings
MP	$\leq 15' \leq 10'$	$\leq 17' \leq 12'$	See page 11
TR	$\leq 5' \leq 3'^{\text{①}}$	$\leq 7' \leq 5'^{\text{①}}$	
Available types	053 - 060 - 080 - 105 - 130 - 160 - 190		
Available versions	In - line, double shaft (IS), input right angle (G), output double right angle (MB)		

① The TR 053 series is not available with 3' backlash on 1-2 stages and 5' on 3 stages

Output backlash is calculated by applying a torque at input corresponding to 2% of the rated torque of the gearbox

Stage	Ratios 053	Ratios 060 - 080 - 105 - 130 - 160 - 190	Efficiency %
1	3-4-5-6-7-9	3-4-5-6-7-10	η 0.97
2	12-15-16-18-20-24-25-28-30-35-36-42-45-54-81	9-12-15-16-18-20-24-25-28-30-35-36-40-42-50-60-70-100	η 0.94
3	48-60-64-75-80-84-100-112-125-140-144-162 175-180-216-225-245-252-324-405-567-729	48-64-75-80-84-90-120-125-140-144-150-160-175 180-200-210-216-250-280-350-400-500-700-1000	η 0.90

Ratios		Torque Nm	Type						
053	060 - 190		053	060	080	105	130	160	190
3-9-81-729	3-9-10-90-100-1000	C _{N2}	12	18	40	100	215	350	500
		C _{A2}	22	35	80	180	400	660	800
		C _{P2}	40	70	180	360	800	1200	1400
4-5-6-7-18-30-36	4-5-6-7-18-30-36	C _{N2}	15	25	50	140	380	500	700
		C _{A2}	28	40	80	210	600	750	950
		C _{P2}	45	90	200	450	1100	1400	1800
12 - 15 - 16 - 20 - 24 - 25 - 28 35 - 42 - 45 - 48 - 54 - 60 - 64 75 - 80 - 84 - 100 - 112 - 125 140 - 144 - 162 - 175 - 180 - 216 225 - 245 - 252 - 324 - 405 - 567	12 - 15 - 16 - 20 - 24 - 25 - 28 35 - 40 - 42 - 48 - 50 - 60 - 64 70 - 75 - 80 - 84 - 120 - 125 - 140 144 - 150 - 160 - 175 - 180 - 200 210 - 216 - 250 - 280 - 350 - 400 500 - 700	C _{N2}	20	30	70	170	450	700	1000
		C _{A2}	30	45	100	250	700	950	1200
		C _{P2}	60	100	250	600	1300	1800	2200

C_{N2} - Rated torque: continuous torque capacity at rated speed

CA2 - Starting torque: allowed during duty cycle with using coefficient < 60% - (see page 10)

CP2 - Emerg. stop torque: starting torque occurring less than 1,000 times over reducer life

Ratios		Nominal speed (rpm) ② Continuous duty (S1)							Maximum speed (rpm) ③ Intermittent duty (S5)						
053	060 - 190	053	060	080	105	130	160	190	053	060	080	105	130	160	190
3-12-15-18	3-9-12-15-18	3000	2500	2200	1900	1200	1000		3500				3000	2000	
4-5-6	4-5-6	3300	2900	2500	2100	1500	1200							3500	2500
7-9-216	7-10-36-216	4000	3100	2800	2600	2300	1700								
16-20-24-25-30-48 64-75-80-100-125	16-20-24-25-28-30-48 60-64-75-80-144-180	4400	3500	3100	2900	2700	2100								
28-35-36-42-45-54 60-84-112-140-144 162-175-180-225-245 252-324-405-567	35-40-42-50-70-84-90 120-125-140-150-160 175-200-210-250-280 350-400-500-700	4800	3800	3500	3200	2900	2300		6000			4500	4000	4000	3500
81-729	100-1000	5500	4500	4200	3900	3400	2500								

② Nominal speed for utilisation to cycles with using coefficient $\geq 60\%$ - (see page 10)

③ Available speed only for cycles/h < 1000

			053	060	080	105	130	160	190
MP	Torsional rigidity (Nm/arc min)	St.1	1	3	7	22	43	90	130
		St.2	0.9	2.5	5.9	20.5	37.5	83	100
		St.3	0.7	1.8	5.4	17.5	29.5	60	90
	Maximum radial load ①	N	500	600	1300	1500	5500	6500	14000
	Maximum axial load	N	600	700	1400	1600	6500	7500	15000
TR	Torsional rigidity (Nm/arc min)	St.1	1	3	8	24	45	90	130
		St.2	0.9	2.5	6.5	21.5	38.5	83.5	100
		St.3	0.7	2	5.5	18	30	60	90
	Maximum radial load ①	N	500	600	2500	3800	5500	6500	14000
	Maximum axial load	N	600	700	3000	4000	6500	7500	15000

To calculate axial and radial loads refer to page 11
 ① Load applied to output shaft center line at 100 rpm

			053	060	080	105	130	160	190
Bearings average term			20.000 hours						
Reversibility torque (Nm) (Reference value)	St.1		0.3	0.4	0.5	0.9	1.2	1.3	3
	St.2		0.5	0.6	0.8	2.5	5	6	7.5
	St.3		3	3.5	5	10	20	23	28
Lubrication			Synthetic oil with ISO VG220 viscosity						
Operating temperature			-10°C / +90°C						
Rotation sense			Concordant to input and output						
Assembly position			To be indicated in the order using the purchase code						
Protection			IP 65						
Max. noise level			≤ 70 dB (A)						

Ratio ∅ Motor shaft	Inertia moment referred to motor input (Kg cm ²)											
	3	4	5	6-7	② 9-10	9	15-20	24-30	35-48	50-100	> 100	
053	6-11	0.28	0.18	0.17	0.16	0.15	0.35	0.16	0.15	0.12	0.11	0.11
	12-14	0.32	0.19	0.18	0.17	0.16	0.39	0.20	0.19	0.16	0.14	0.14
060	6-11	0.28	0.18	0.17	0.16	0.15	0.35	0.16	0.15	0.12	0.11	0.11
	12-14	0.32	0.19	0.18	0.17	0.16	0.39	0.20	0.19	0.16	0.14	0.14
080	9-11	0.74	0.54	0.46	0.40	0.37	0.75	0.48	0.47	0.36	0.35	0.35
	12-14	0.85	0.59	0.51	0.45	0.42	0.86	0.54	0.52	0.41	0.39	0.39
	15-19	0.92	0.65	0.57	0.51	0.48	0.98	0.61	0.58	0.48	0.46	0.46
105	12.7-14	2.55	1.72	1.46	1.12	1.05	3.10	1.71	1.71	1.12	1.12	1.12
	15-19	3.35	1.83	1.54	1.28	1.18	4.48	1.82	1.82	1.23	1.23	1.23
	22-24	4.53	2.58	2.28	1.91	1.83	5.36	2.54	2.54	1.90	1.90	1.90
	28	5.82	3.34	3.03	2.76	2.67	6.36	3.32	3.32	2.71	2.71	2.71
	32	6.92	4.46	4.16	3.85	3.72	7.38	4.42	4.42	3.81	3.81	3.81
130	14	5.41	5.05	3.92	2.33	1.89	6.21	3.42	3.41	1.97	1.95	1.95
	15-19	6.15	5.75	3.85	3.11	2.58	6.98	4.15	4.14	2.94	2.92	2.92
	22-24	8.62	8.21	6.36	5.58	5.10	9.22	6.62	6.60	4.98	4.96	4.96
	28-32	10.12	8.42	6.57	5.76	5.22	10.86	6.84	6.82	4.87	4.85	4.85
	38	12.42	10.00	8.18	7.38	6.81	12.54	8.48	8.47	6.47	6.45	6.45
160	14	26.45	16.54	10.10	9.36	8.46	27.25	15.36	10.08	9.16	7.66	7.66
	15-19	29.82	19.78	12.87	11.22	9.35	30.75	17.96	12.64	11.02	8.55	8.55
	22-24	31.81	23.36	16.58	12.77	10.28	32.92	21.52	16.32	12.56	9.62	9.62
	28-32	33.64	25.18	18.35	14.51	12.60	34.46	23.78	18.15	14.28	11.81	11.81
	38	37.65	28.69	22.18	16.12	14.32	38.24	26.92	21.96	15.88	13.52	13.52
190	19-32	40.33	32.20	26.44	20.68	18.46	41.12	30.24	26.22	20.42	17.62	17.62
	35-38	42.53	34.83	28.86	21.32	19.55	43.32	32.88	28.76	21.15	18.52	18.52
	42-48	46.82	38.85	32.93	26.72	23.60	47.54	36.88	32.82	26.46	22.33	22.33

② Ratio 1:9 - 1 stage available for MP-TR 053

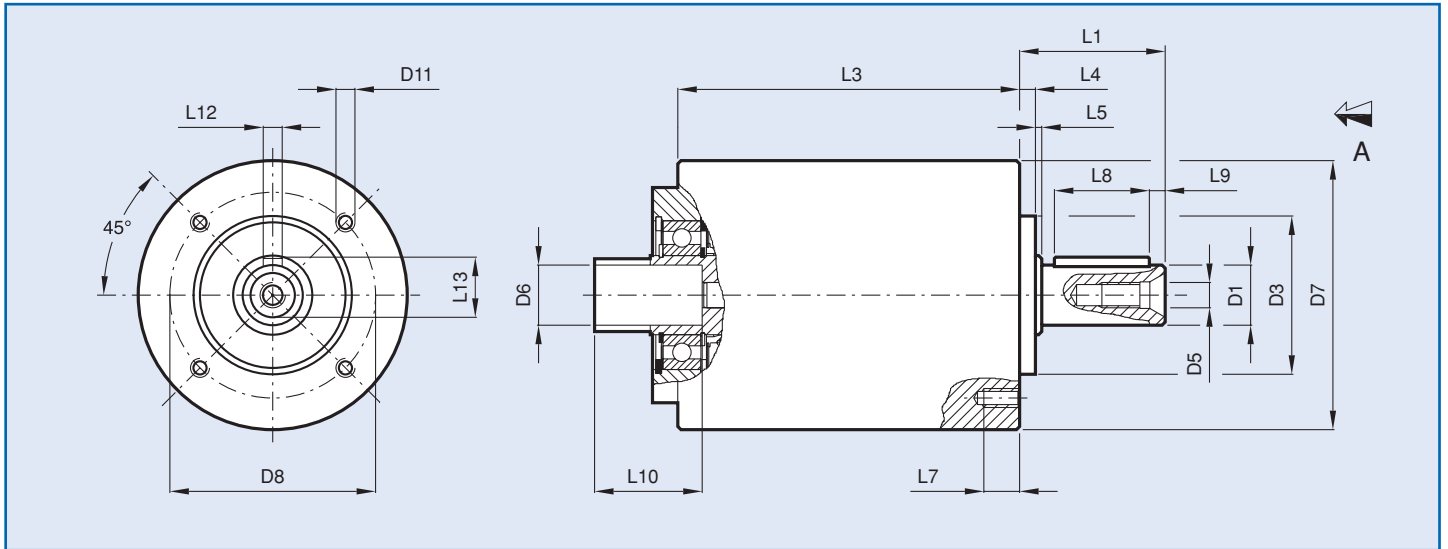

	053	060	080	105	130	160	190 ^②
D1 (h7)	12	14	19	25	32	40	55
D3 (h7)	32	40	50	70	80	110	180
D5	M4 x 10	M5 x 13	M6 x 16	M10 x 25	M12 x 32	M12 x 32	M14 x 36
D6 (F7) ^①	6 - 6.35	6 - 6.35	9 - 9.52	12.7 - 14	14 - 15.875	14 - 15.875	19 - 24
	7 - 8	7 - 8	11 - 12	15.875 - 16	16 - 19	16 - 19	32 - 35
	9 - 9.52	9 - 9.52	12.7 - 14	19 - 22	22 - 24	22 - 24	38 - 42
	11 - 12	11 - 12	15.875 - 16	24 - 28	28 - 32	28 - 32	45 - 48
	12.7 - 14	12.7 - 14	19	32	35 - 38	35 - 38	
D7	55	65	85	106	138	155	185
D8 ±0.05	40	52	65	85	110	130	215
D11	M5	M5	M6	M8	M12	M12	∅13
L1	24.5	36.5	46	57.5	69.5	93	96
L3	ST.1	53	57.55	83.5	107.5	126	171.7
	ST.2	66.8	74.25	108	140	165.5	223.4
	ST.3	80.6	90.95	132.5	172.5	205	275.1
L4	3	3	5	5	7	9	13
L5	2.5	3.5	2	2	8	2	2
L7	10	10	12	12	18	18	15
L8	14	20	30	35	50	70	60
L9	2.5	5	5	5	3	6	11
L10	21.5	21.5	34	35.5	40	40	50
L12	4	5	6	8	10	12	16
L13	13.5	16	21.5	28	35	43	59
Weight Kg	ST.1	0.8	1.2	4	6.5	12	25
	ST.2	1.0	1.7	4.6	8.5	15.5	29
	ST.3	1.3	2.0	5.2	10.5	18.5	34

① Bushes available for fitting on motor shafts according to motor size

② Only on MP-TR 190: squared output side 195x195, flange 14 mm thick

The list of the motor counterflanges is on pages 4 and 5.

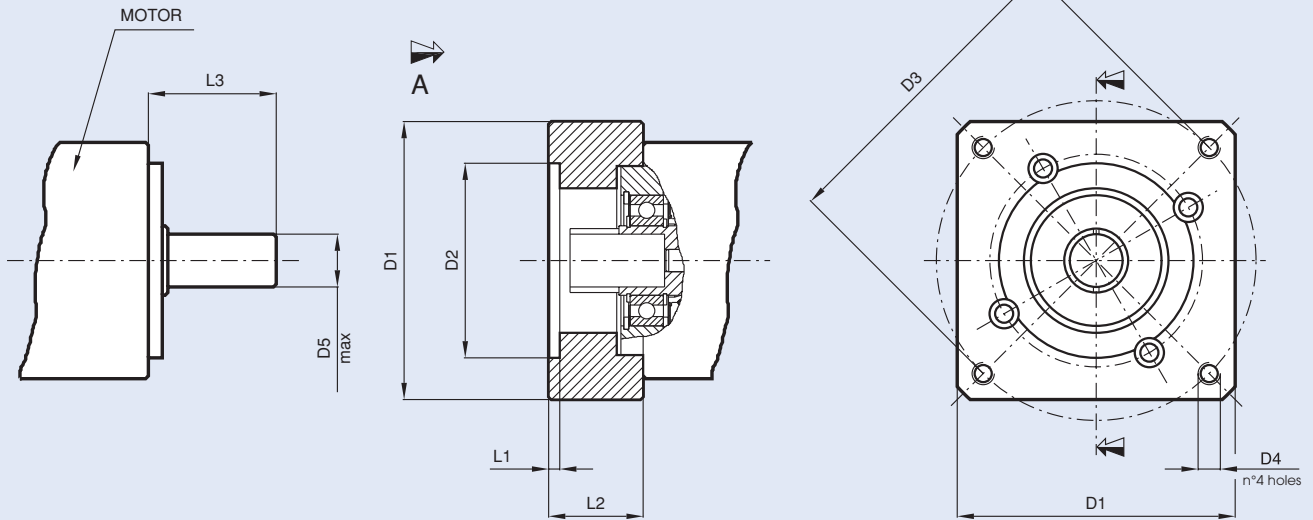
COUPLING
NOTE

Remove the key from motor shaft (dwg. 2), the shaft is secured via a joint and a screw, to be tightened to the torque wrench settings specified on the assembly instructions

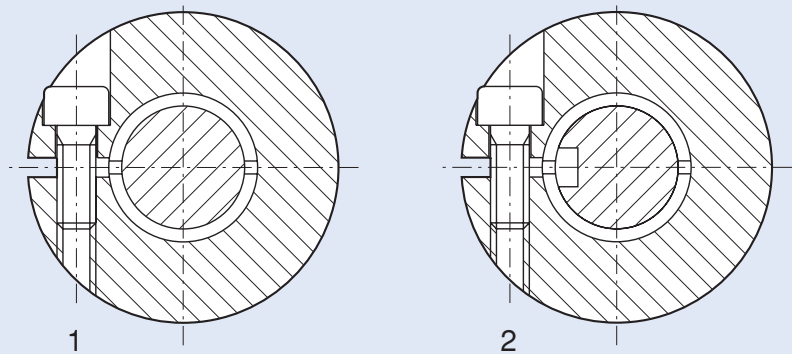

Cod	D1	D2	D3	D4	D5 max	L1	L2	L3	Type
STD053	55	25/40	36/56	4,5	9	---	25	25	053
STD060	65	25/40	36/56	4,5	9	---	25	25	060
NEMA23.060	60	38.1	66.6	M4	12	4	18	25	053 060
40/63.060	60	40	63	M4	12	4	18	25	
50/60.060	60	50	60	M4	12	4	18	25	
56B14.060 ①	60	50	65	M5	14	4	23	30	
50/70.060	60	50	70	M5	14	4	23	30	
63B14.060	65	60	75	M5	14	4	23	30	
60/90.060	75	60	90	M5	14	4	23	30	
71B14.060	75	70	85	M6	14	4	23	30	
70/90.060	75	70	90	M5	14	4	23	30	
NEMA34.060	85	73	98.4	M5	14	4	25	32	
56B5.060	85	80	100	M6	14	4	23	30	

① On MP-TR 060 version for motors featuring threaded holes (B14) and oversized L2 (2 mm) available

Cod	D1	D2	D3	D4	D5 max.	L1	L2	L3	Type
56B14.080 ①	80	50	65	M5	14	5	34	40	080
50/70.080	80	50	70	M5	14	5	34	40	
50/95.080	80	50	95	M6	14	5	34	40	
NEMA42B.080	105	55.5	125.7	M6	19	5	34	40	
63B14.080 ①	80	60	75	M6	19	5	34	40	
60/90.080	80	60	90	M5	16	5	34	40	
71B14.080 ①	80	70	85	M6	19	5	34	40	
PAM70.080	80	70	90	M5	19	5	34	40	
NEMA34.080	85	73	98.4	M5	14	5	34	40	
78/63.5.080	85	78	63.5	M6	14	5	34	40	
56B5.080	90	80	100	M6	19	5	34	40	
63B5.080	100	95	115	M8	19	5	34	40	
95/130.080	115	95	130	M8	19	5	34	40	
71B5.080	115	110	130	M8	19	5	34	40	
S4000.080.50	120	110	145	M8	19	6.5	44	50	
S4000.080.60	120	110	145	M8	19	6.5	54	60	
50/95.105	100	50	95	M6	19	5	28	40	
NEMA42B.105	105	55.5	125.7	M6	19	5	28	40	
63B14.105 ②	100	60	75	M6	19	5	28	40	
71B14.105 ②	100	70	85	M6	19	5	28	40	
PAM70.105	100	70	90	M5	19	5	28	40	
56B5.105	100	80	100	M6	19	5	28	40	
63B5.105.40	100	95	115	M8	19	5	28	40	
63B5.105.50	100	95	115	M8	24	5	38	50	
95/130.105	115	95	130	M8	19	5	28	40	
71B5.105.40	115	110	130	M8	19	5	28	40	
71B5.105.50	115	110	130	M8	24	6.5	38	50	
S4000.105.50	120	110	145	M8	24	6.5	38	50	
S4000.105.60	120	110	145	M8	24	6.5	48	60	
90B5.105.50	140	130	165	M10	24	5	38	50	
90B5.105.60	140	130	165	M10	32	5	48	60	
NEMA42B.130	130	55.5	125.7	M6	19	5	39.5	50	130
56B5.130	130	80	100	M6	19	5	39.5	50	
63B5.130	130	95	115	M8	24	5	39.5	50	
71B5.130	130	110	130	M8	24	5	39.5	50	
S4000.130.60	130	110	145	M8	24	6.5	49.5	60	
S6000.130.80	170	114.3	200	M12	38	6.5	69.5	80	
90B5.130.50	140	130	165	M10	24	5	39.5	50	
90B5.130.60	140	130	165	M10	32	5	49.5	60	
100B5.130.60	190	180	215	M14	32	5.5	49.5	60	
100B5.130.80	190	180	215	M14	38	5.5	69.5	80	
NEMA42B.160	140	55.5	125.7	M6	19	5	39.5	50	160 190
56B5.160	140	80	100	M6	19	5	39.5	50	
63B5.160	140	95	115	M8	24	5	39.5	50	
71B5.160	140	110	130	M8	24	5	39.5	50	
S4000.160.60	140	110	145	M8	24	6.5	49.5	60	
S6000.160.80	170	114.3	200	M12	38	6.5	69.5	80	
90B5.160.50	140	130	165	M10	24	5	39.5	50	
90B5.160.60	140	130	165	M10	32	5	49.5	60	
100B5.160.60	190	180	215	M14	32	5.5	49.5	60	
100B5.160.80	190	180	215	M14	38	5.5	69.5	80	

① Version for motors featuring threaded holes (B14)

② Version for motors featuring threaded holes (B14) and oversized L2 (5 mm) available

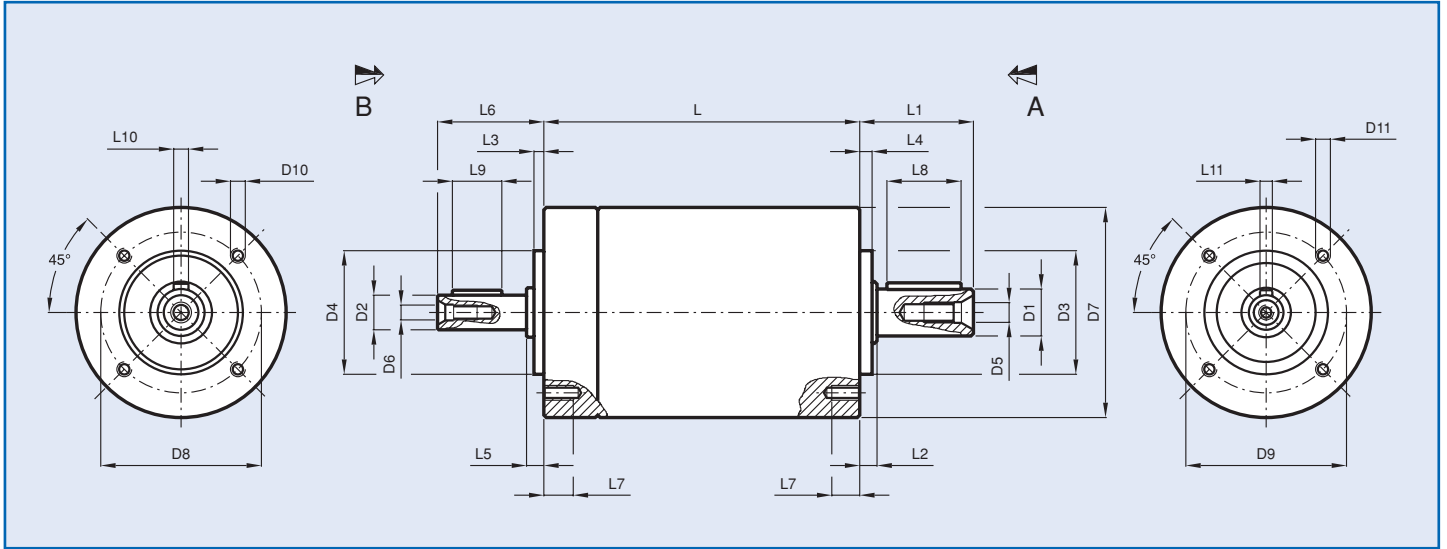

		053	060	080	105	130	160
D1 (h7)		12	14	19	25	32	40
D2 (h7)		12	12	14	19	25	32
D3 (h7)		32	40	50	70	80	110
D4 (h7)		32	32	50	70	80	110
D5		M4 x 10	M5 x 13	M6 x 16	M10 x 25	M12 x 32	M12 x 32
D6		M4 x 13	M4 x 13	M5 x 16	M6 x 20	M10 x 25	M12 x 32
D7		55	65	85	106	138	155
D8 ±0.05		40	52	65	85	110	130
D9 ±0.05		40	40	65	85	110	130
D10		M5	M5	M6	M8	M12	M12
D11		M5	M5	M6	M8	M12	M12
L	ST.1	58.2	62.75	105.3	121.3	151.2	155.2
	ST.2	72	79.45	129.8	153.8	190.7	194.7
	ST.3	85.8	96.15	154.3	186.3	230.2	234.2
L1		24.5	36.5	46	57.5	69.5	93
L2		5.5	6.5	7	7	15	11
L3		2.5	2.5	4	4	5	5
L4		3	3	5	5	7	9
L5		4.5	4.5	7	7	7	7
L6		25	25	43	47	57.5	61.5
L7		10	10	12	12	18	18
L8		14	20	30	35	50	70
L9		14	14	20	30	35	50
L10 (h7)		4	5	6	8	10	12
L11 (h7)		4	4	5	6	8	10
Weight Kg	ST.1	0.8	1.2	4	6.5	12	17
	ST.2	1.0	1.7	4.6	8.5	15.5	21
	ST.3	1.3	2.0	5.2	10.5	18.5	28

For motor input shaft inertia values, please refer to page 2. Values are for motor shaft featuring the following diameters: 11 mm (053, 060, 080), 19 mm (105, 130, 160)

Radial load (N) ^①	200	200	400	600	800	1200
------------------------------	-----	-----	-----	-----	-----	------

① Radial load at mid length of input shaft

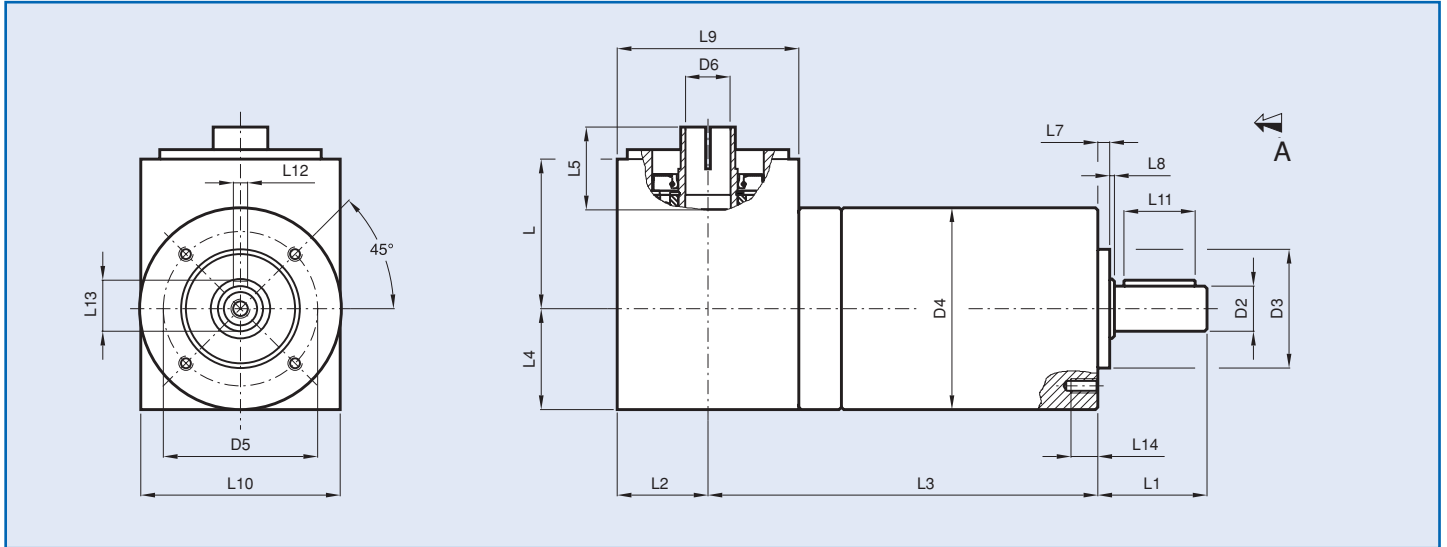

		053	060	080	105	130	160
D2 (h7)		12	14	19	25	32	40
D3 (h7)		32	40	50	70	80	110
D4		55	62	85	106	138	155
D5 ±0.05		40	52	65	85	110	130
D6 (F7)		See table page 3					
L		40	40	53.45	62.65	75.5 ^①	80 ^②
L1		24.5	36.5	46	57.5	69.5	93
L2		27.1	27.1	38.25	49	62	62
L3	ST. 1	88.9	93.45	143.55	170.3	213.2	218.2
	ST. 2	102.7	110.15	168.05	202.8	252.7	257.7
	ST. 3	116.5	126.85	192.55	235.3	292.2	297.2
L4		27.5	27.5	42.5	53	69	77.5
L5		21.5	21.5	34	35.5	40	58
L7		3	3	5	5	7	9
L8		2.5	3.5	2	2	8	2
L9		63	63	76.5	98	124	124
L10		55	55	80	98	124	137
L11		14	20	30	35	50	70
L12 (h7)		4	5	6	8	10	12
L13		13.5	16	21.5	28	35	43
L14 (4 holes)		M5x10	M5x10	M6x12	M8x12	M12x18	M12x18
Weight Kg	ST. 1	1.3	1.7	5.2	8.5	16	24
	ST. 2	1.5	2.2	5.8	10.5	19.5	28
	ST. 3	1.8	2.5	6.4	12.5	22.5	34

Specifications on motor counter flanges and bushes are shown on pages 3, 4 and 5 (in-line gearboxes).

For motor shaft (input) inertia values, please refer to page 2. Values are for motor shaft featuring the following diameters: 14 mm (053, 060), 19 mm (080), 28 mm (105, 130, 160)

① For motor shafts having 35-38 diameter the value is 76.5 mm

② For motor shafts having 35-38 diameter the value is 81 mm

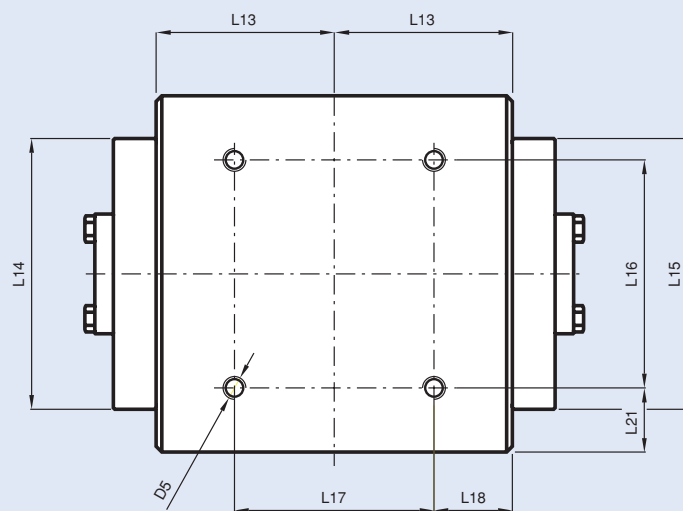
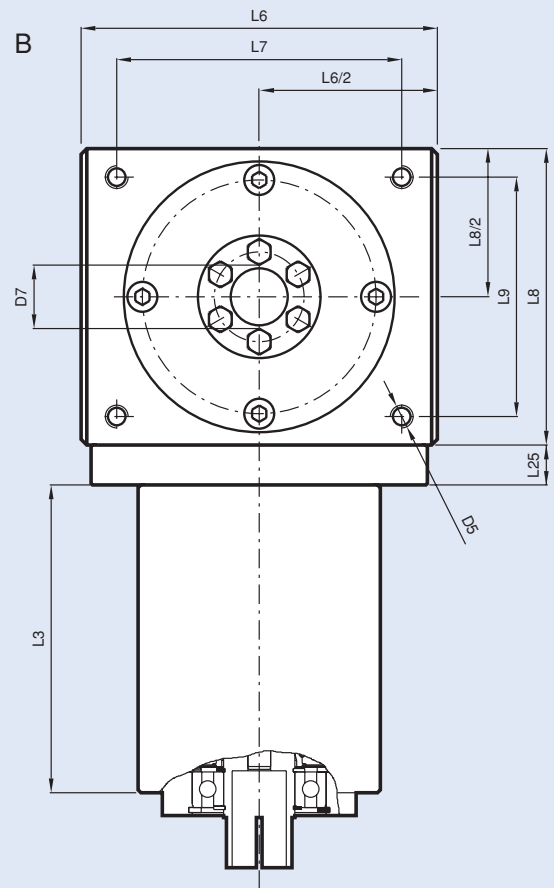
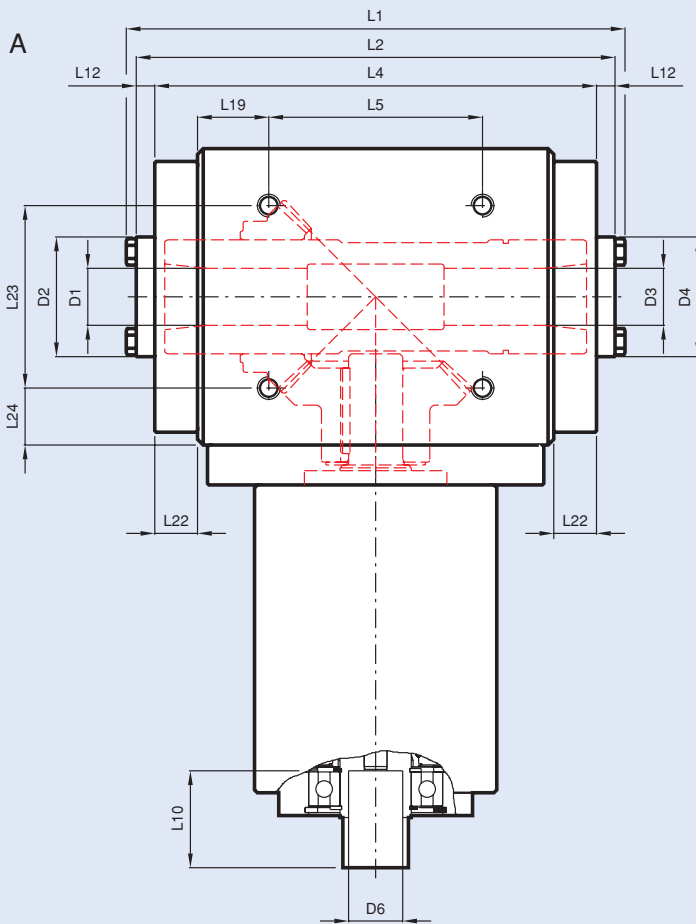

	080	105	130	160	
L1	175	212	264	264	
L2	168	204	254	254	
L3	see table page 3				
L4	155	190	225	225	
L5	75	95	100	100	
L6	125	160	185	185	
L7	100	124	145	145	
L8	104	145	175	175	
L9	84	124	145	145	
L10	see table page 3				
L12	6.5	7	14.5	14.5	
L13	62.5	80	92.5	92.5	
L14	95	144	172	172	
L15	95	144	172	172	
L16	80	95	100	100	
L17	70	95	100	100	
L18	27.5	32.5	42.5	42.5	
L19	25	32.5	42.5	42.5	
L21	22.5	32.5	42.5	42.5	
L22	15	15	20	20	
L23	64	95	100	100	
L24	20	25	37.5	37.5	
L25	14	15	20	20	
D1 (h7)	20	32	42	42	
D2	42	58	75	75	
D3 (h7)	20	32	42	42	
D4	42	58	75	75	
D5	M8	M10	M12	M12	
D6 (F7)	See table page 3				
D7	22	34	47	47	
Weight Kg	St. 1	14	32	54	54
	St. 2	15	34	58	58
	St. 3	16	36	61	61

Specified torque values (as shown on page 1) are guaranteed only if the shaft is secured to both output shrink discs.

Gearbox output axial load (N)	080	105	130	160
1000 rpm	4000	6000	9000	9000
500 rpm	4500	6800	10500	10500
300 rpm	5000	7200	11500	11500

Gearbox output radial load (N) ①	080	105	130	160
1000 rpm	4500	6500	10000	10000
500 rpm	5000	7300	11500	11500
300 rpm	5500	8000	12500	12500

① Values referring to a radial load at a certain distance from the gearbox: 080/60 mm, 105/80 mm, 130/100 mm.
Specifications on motor counter flanges and bushes are shown on pages 3, 4 and 5 (in-line gearboxes).

Apart from handled loads and motor specifications, **UC** (use coefficient) is of major importance for the selection of the right gearbox, that is the percentage of time during which the gearbox is running over the whole working cycle time.

For example (A = acceleration, C = steady speed, D = deceleration, P = breakdown):

$$(A = 1 \text{ sec}) + (C = 2 \text{ sec}) + (D = 1 \text{ sec}) + (P = 6 \text{ sec}) = 10 \text{ sec (UC 40\%)}$$

$$(A = 2 \text{ sec}) + (C = 2 \text{ sec}) + (D = 2 \text{ sec}) + (P = 2 \text{ sec}) = 8 \text{ sec (UC 75\%)}$$

The duty cycle can be **S5** (intermittent) or **S1** (continuous) as per the following:

	Number of accelerations per hour ≤ 1000	Number of accelerations per hour > 1000
UC < 60%	S5	S1
UC $\geq 60\%$	S1	S1

For a quick selection of the size it is also necessary to determine the frequency of accelerations per hour (Z), and consider the suitable safety factor (fz), if necessary, as shown in the following table:

Number of accelerations per hour (Z)	Safety factor (fz)
$Z \leq 1000$	1.00
$1000 < Z \leq 1500$	1.25
$1500 < Z \leq 2000$	1.50
$2000 < Z \leq 2500$	1.75
$2500 < Z \leq 3000$	2.00
$Z > 3000$	Contact Tecnoingranaggi Riduttori

Outcomes from this operation should be compared with max. torques specified on page 1; discriminating intermittent cycles from continuous cycles, compare the former with start values and the latter with nominal values.

Duty cycle	Comparing values
S5	$C_{A2} \geq M_{1MAX} \cdot R \cdot \eta \cdot fz$
S1	$C_{N2} \geq M_{1MAX} \cdot R \cdot \eta \cdot fz$

- C_{A2} = Starting torque (see page 1)
- C_{N2} = Rated torque (see page 1)
- η = Efficiency (see page 1)
- M_{1MAX} = Motor max. acceleration torque
- R = Reduction ratio
- fz = Safety factor (fz)

As far as S1 use is concerned, for working cycles requiring steady rpm values for a long time, during which gearbox is subject to overheating, seals for high temperatures are warmly recommended as well as a suitable cooling system and compliance with motor rpm values specified on page 1 (S1 rated rotation speed).

Bearing duty life (hours) may be calculated through formulae which take into account radial and axial load value and position when using stiff ball bearings (**CS**) or taper roller bearings (**CR**).

	053	060	080	105	130	160	190
MP	CS	CS	CS ①	CS ①	CR	CR	CR
TR	CS	CS	CR	CR	CR	CR	CR

① CR optional available

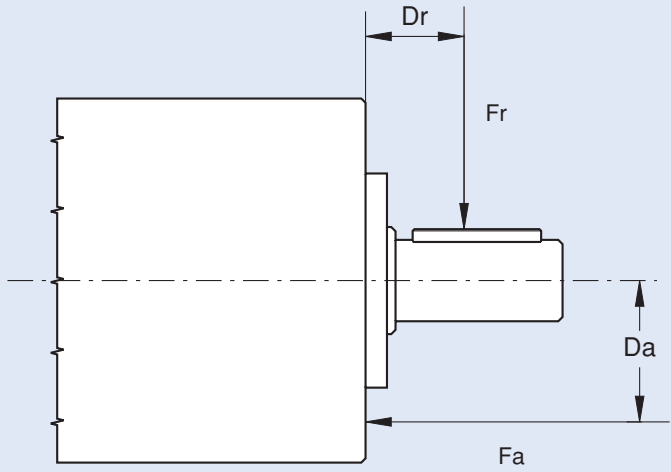

Fa Axial load (N)

Fr Radial load (N)

Da Distance between axial load and gearbox center (mm)

Dr Distance between radial load and flange surface (mm)

K Constants for different gearbox sizes (see table)

m Gearbox output revolutions (rpm)

Lh Bearings average term (h)

STIFF BALL BEARINGS (CS)

$$F_1 = \frac{F_a \cdot D_a + F_r \cdot (D_r + K_2)}{K_1}$$

$$L_h = \frac{16666}{m} \cdot \left(\frac{K_3}{F_1} \right)^3$$

Constant	053	060	080	105
K1	15.5	14.4	21.5	24.5
K2	17	17.4	32.3	36
K3	5600	9550	14000	25700

The: $e \leq 0.19$ condition should be met where $e = \frac{F_a}{F_1}$ - When the $e > 0.19$ condition occurs, please contact Tecnoingranaggi Riduttori

TAPERED ROLLER BEARINGS (CR)

$$F_1 = \frac{F_a \cdot D_a + F_r \cdot (D_r + K_2)}{K_1}$$

$$L_h = \frac{16666}{m} \cdot \left(\frac{K_3}{F_1} \right)^{10/3}$$

Constant	080	105	130	160	190
K1	28	35	45	52	62
K2	35.55	41.25	51.75	56.75	64.25
K3	30800	51200	76500	99000	140000

The: $e \leq 0.4$ condition should be met where $e = \frac{F_a}{F_1}$ - When the $e > 0.4$ condition occurs, please contact Tecnoingranaggi Riduttori

To order our product, mention the full reference code:

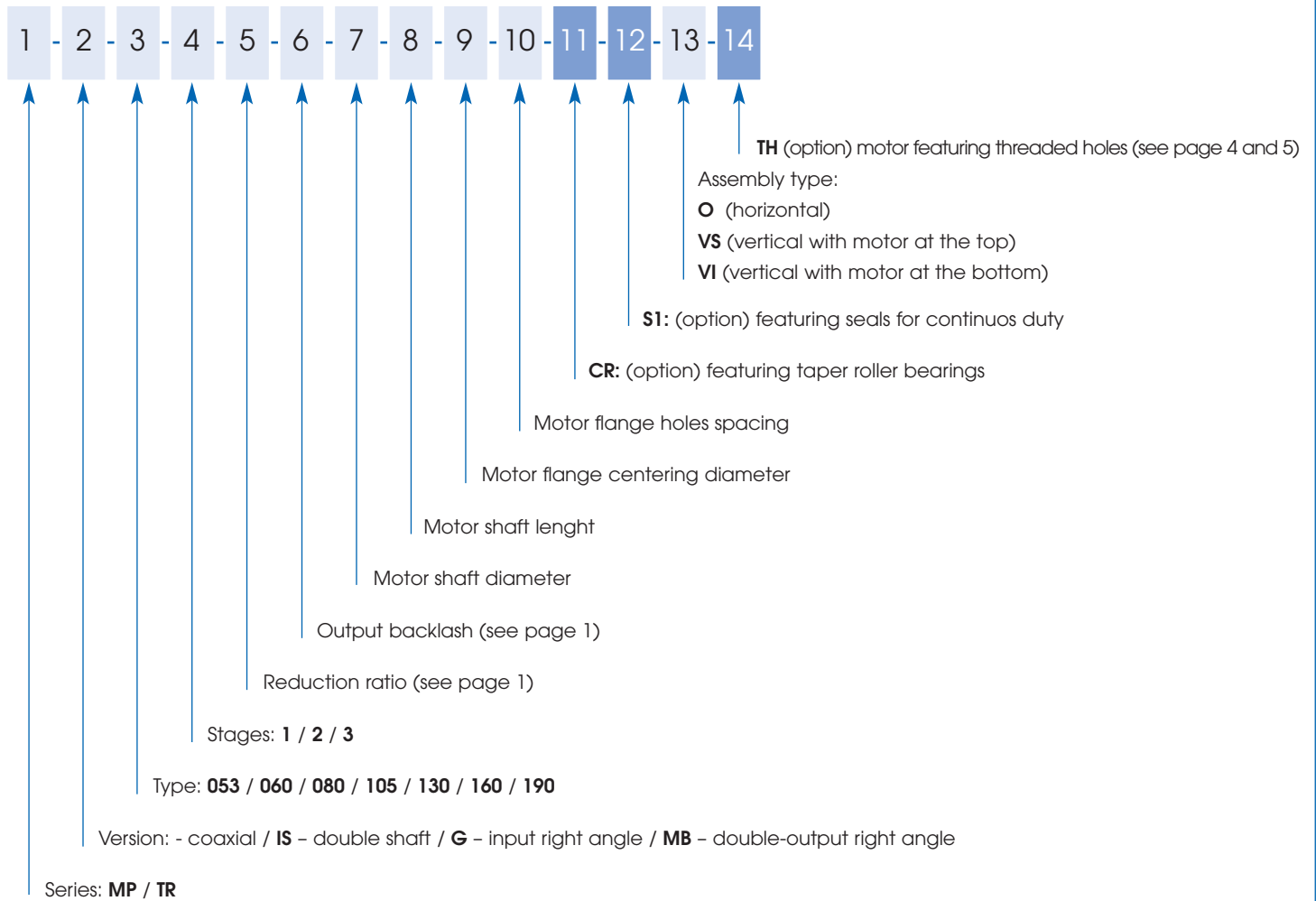

How to create the code for identifying a gearbox

- 1 - Series: **MP**
- 2 - Right angle version: **G**
- 3 - Type: **080**
- 4 - Stages: **2**
- 5 - Reduction ratio: **70**
- 6 - Output backlash: **10'**
- 7 - Motor shaft diameter: **mm 14**
- 8 - Motor shaft length: **mm 30**
- 9 - Motor flange centering diameter: **mm 60**
- 10 - Motor flange holes spacing: **mm 75**
- 11 - Tapered roller bearings option **CR**
- 12 - Option not required
- 13 - Horizontal mounting: **○**
- 14 - Option not required

The code corresponding to the above requirements is as follows:

MP - G - 080 - 2 - 70 - 10' - 14 - 30 - 60 - 75 - CR - ○